

Read me
FIRST

www.CookWithKenyon.com

KENYON®

Make any day a weekend

2B SiIKEN® INDUCTION COOKTOPS
OWNERS MANUAL

Part# 143699
Created: May 25, 2010
Revised: December 30, 2010

Table of Contents

Section	Page
Safety Guidelines	1
Product Specifications	3
Installation Instructions	
Step # 1 - Unpacking the Cooktop	4
Step # 2 - Checking the Electrical Supply Requirements	5
Step # 3 - Countertop Preparation	5
Step # 4 - Installing the Cooktop	7
Step # 5 - Electrical Connection	8
Step # 6 - Final Preparations Prior to Use	8
Operation of SILKEN® Induction Cooktop	
Induction Cooking	9
Cookware	9
Benefits of Induction Cooking	9
Lock Mode.....	10
Initial Start-up	10
Controls of Induction Cooktop	11
Heat Boost Mode	11
Hot Surface Indicator	11
Safety Thermal Cutout	12
Master Off	12
Cooling Fan	12
Temperature Setting Guide	12
Cleaning	13
Maintenance	13
Troubleshooting Guide	13
Warranty Information	15

Kenyon International, Inc.
8 Heritage Park Road
P.O. Box 925
Clinton, CT 06413 USA
Phone: 860-664-4906
www.CookWithKenyon.com

SAFETY GUIDELINES

Please read these instructions in their entirety before installation and use. The following information applies to all KENYON Electric Cooktops.

This cooktop, like all appliances, has the potential to create safety problems through careless and improper use. Please observe all of the following safety precautions.

Proper Installation.

Be sure your appliance is properly installed and grounded by a qualified technician.

Never use your appliance for warming or heating the room.

CAUTION

Do not leave children alone.

Children should never be left alone or unattended in the area where the appliance is in use. They should never be allowed to sit or stand on any part of the appliance. Do not let children play with cooktop. Do not store items of interest to a child in cabinets above the cooktop, children climbing on the cooktop to reach such items could be seriously injured.

Wear proper clothing/apparel.

Loose fitting or hanging garments should never be worn while using the appliance. Fabric or other flammable materials may contact hot surfaces during operation and may ignite and result in personal injury.

User Servicing

Do not repair or replace any part of the appliance. If service ever becomes necessary, this appliance should be serviced by **AUTHORIZED PERSONNEL ONLY** or call **KENYON Customer Care** at **(860)664-4906**.

Storage in or on Appliance

Flammable materials should not be stored above, under or near surface cooking units.

Keep flammable materials away from cooktop.

Do not store plastic material (such as plastic utensils) in storage areas beneath cooktop.

Plastic items with low melting temperatures should not be stored under/over or near the cooktop.

Do not use water on grease fires.

Smother fire or flame or use dry chemical or foam-type extinguisher.

Use only dry pot holders.

Moist or damp pot holders on hot surfaces may result in burns from steam. Do not let pot holders touch the induction elements on the appliance. Do not use a towel or other bulky cloth in place of a pot holder.

Do not cook on broken cooktop.

If cooktop should break, cleaning solutions and spillovers may penetrate the broken cooktop and create a risk of electric shock. Contact an authorized service center or KENYON Customer Care immediately at (860) 664-4906.

Clean cooktop with caution.

Do not clean the cooktop while it is still hot. If a wet sponge or cloth is used to wipe spills on a hot cooking surface, be careful to avoid steam burns. Some cleaners produce noxious fumes if applied to a hot surface. Read the cleaner label for details prior to using.

Use proper pan size.

This appliance is equipped with one or more surface units of different size. Select cookware having flat bottoms large enough to activate the induction unit. Proper relationship of cookware to burner size will also improve efficiency.

Never Leave Surface Units Unattended at High Heat Settings.

Boilover may cause smoking and greasy spillovers may ignite.

Utensil Handles Should be Turned Inward and Not Extend Over Adjacent Surface Units.

To reduce the risk of burns, ignition of flammable materials, and spillage due to unintentional contact with the utensil, the handle of a utensil should be positioned so that it is turned inward, and does not extend over adjacent surface units.

Never heat an empty pan.

It may damage the cooktop or cookware and overheat the unit.

Do not use aluminum foil on the surface of the cooktop.

Cookware should always be dry.

Do not heat cookware with excess water droplets on the outside of the pan. The droplets may begin to boil and splatter.

DO NOT TOUCH SURFACE UNITS OR AREAS NEAR UNITS.

Surface units may be hot even though they are dark in color. Areas near surface may become hot enough to cause burns. During and after use, do not touch, or let clothing or other flammable materials contact surface units or areas near units until they have had sufficient time to cool. Among these areas are the induction elements and surrounding glass surface.

DO NOT DISCARD THESE INSTRUCTIONS, KEEP THEM WITH THE KENYON SIKEN® INDUCTION COOKTOP FOR FUTURE REFERENCE.

SilKEN® Induction Series Cooktop

PRODUCT SPECIFICATIONS

B80101 - 240V AC - one 5.7" (145mm) @ 1400 watts normal, 1800 watts boost
one 8.25" (210mm) @ 2300 watts normal, 3200 watts boost

B80105 - 240V AC - one 5.7" (145mm) @ 1400 watts normal, 1800 watts boost
one 8.25" (210mm) @ 2300 watts normal, 3200 watts boost

B80201 - 240V AC - one 5.7" (145mm) @ 1400 watts normal, 1800 watts boost
one 8.25" (210mm) @ 2300 watts normal, 3200 watts boost

B80205 - 240V AC - one 5.7" (145mm) @ 1400 watts normal, 1800 watts boost
one 8.25" (210mm) @ 2300 watts normal, 3200 watts boost

Overall dimensions: 23 1/2" x 14 1/2" x 3 1/4"

596.9mm x 368.3mm x 82.6mm

Cutout dimensions: 22 7/8" x 12 1/2" with 1/4" radius

581mm x 317.5mm with 6.4 radius

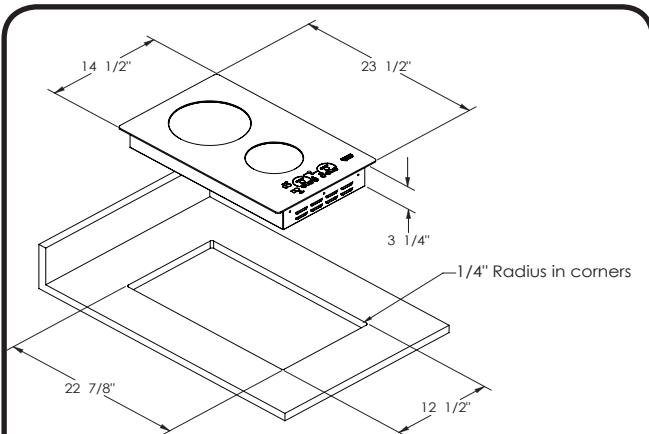

Portrait Models B80101 & B80201

For use in islands and non-standard counters.

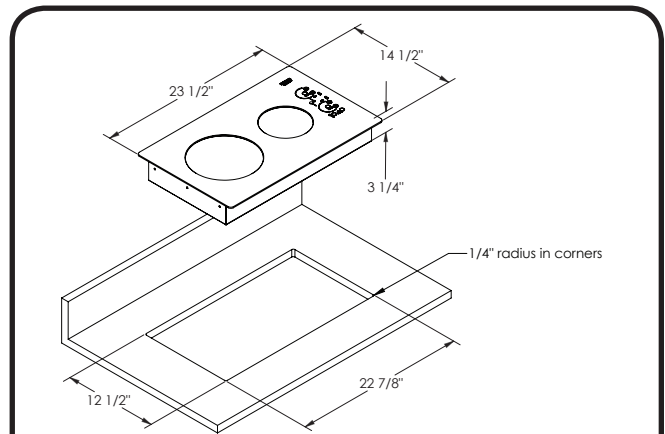

Landscape Models B80105 & B80205

For use in standard 24" depth counters.



Important: Performance of SilKEN® may be compromised if the electrical supply is less than 240 volts.

INSTALLATION INSTRUCTIONS FOR KENYON SiIKEN® INDUCTION COOKTOPS



Important: Save this document for review by local inspector.

Important: This appliance must be properly installed and grounded by a qualified technician.

STEP # 1

Unpacking the Cooktop

Carefully unpack the cooktop from its shipping container. If possible, retain the original shipping carton and protective packaging in the event the unit ever has to be returned for service.

Verify and identify the package contents. The following items should be included in the carton. If any components are missing or damaged, call KENYON immediately.

*SiiKEN® Induction Cooktop • (2) Mounting brackets
(1) Package of mounting screws • (1) Ceramic cooktop cleaner*

SiiKEN® Induction Cooktop

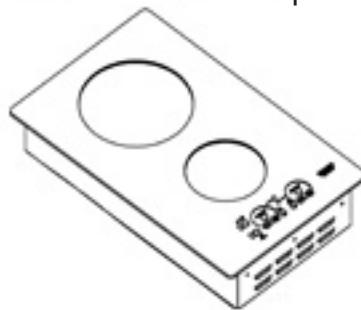

Mounting Brackets



Cerama Bryte
Ceramic Cooktop Cleaner



Mounting Screws Package



Important: Do not remove the clear plastic covering film on the induction glass until cooktop is ready to use.

For future reference, please record the serial number of your cooktop here:

STEP #2

Check the Electrical Supply Requirements

This product must be installed in accordance with national, state and local electric codes. The following table provides the correct voltage, amperage and frequency that must be supplied to the cooktop.

Kenyon Part #	Model #	Max Connected Load	Required Power Supply Input	Minimum Wire Size
B80101	IND2BLG	3700 Watts	240VAC/16A/50/60Hz	#12 AWG
B80105	IND2BLG	3700 Watts	240VAC/16A/50/60Hz	#12 AWG
B80201	IND2BLG	3700 Watts	240VAC/16A/50/60Hz	#12 AWG
B80205	IND2BLG	3700 Watts	240VAC/16A/50/60Hz	#12 AWG

The supply must be from an individual grounded circuit that is protected by a circuit breaker and rated per the specifications for the various models as shown in the table above.



Warning: If the electric power supply does not meet the product specifications, consult with a licensed electrician before proceeding with installation.

Ensure you have the correct model for your countertop. Landscape models are designed for use in standard 24" depth countertops. Portrait models are designed for use in islands and applications with non-standard depth countertops. Generally 25 1/2" minimum countertop depth is needed to install portrait models.

STEP #3

Countertop Preparation

Please read this section prior to making cutout for cooktop.

It is important to plan ahead for installation of the cooktop, keeping the following dimensions in mind (please refer to Figure A).

- A - 13 inches maximum depth of overhead cabinets
- B - 36 inches is minimum height of countertop above floor
- C - The minimum flat countertop surface that the cooktop will rest upon must be equal to or greater than the overall cooktop dimensions (refer to the following page for overall cooktop dimensions).
- D - 30 inches minimum clearance between the top of the cooking surface and the bottom of an unprotected wood or metal cabinet or 24 inch minimum clearance when the bottom of the wood or metal cabinet is protected by not less than 1/4-inch-thick flame retardant millboard covered with not less than No. 28 MSG sheet steel, 0.015-inch-thick stainless steel, 0.024-inch-thick aluminum or 0.020-inch-thick-copper.
- E - 1-inch minimum from backsplash of countertop to edge of glass (refer to the following page for overall cooktop dimensions).

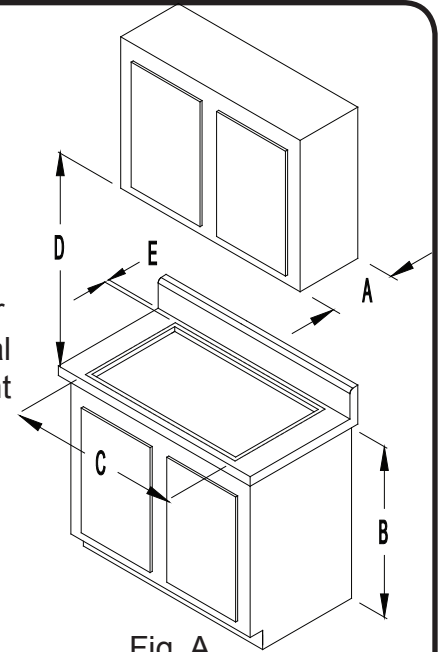

Fig. A

FOR INSTALLATIONS IN CANADA: “Do Not Install Closer Than 1/2 Inch (12mm) From Any Adjacent Surface”, and **NE PAS INSTALLER A’MDINS DE 12MM DETOUTE SURFACE ADJACENTE.**



Warning: To eliminate the risk of burns by reaching over heated surface units, cabinet storage space located above surface units should be avoided. If cabinet storage is to be provided, the risk can be reduced by installing a range hood that projects horizontally a minimum of 5” beyond the bottom of the cabinets.

Before making the countertop cutout, check for clearance. Check to see if the cooktop will clear the front and side walls of the base cabinet. It is also important to provide enough ventilation.

Adequate ventilation of the space below the countertop must be provided to ensure proper operation of the cooktop. Heat transferred from the cooktop bottom pan during operation will overheat an improperly ventilated area.

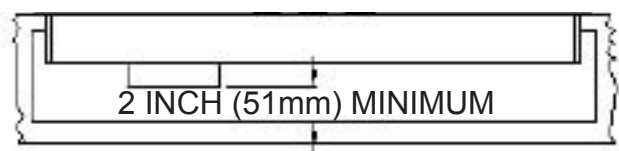
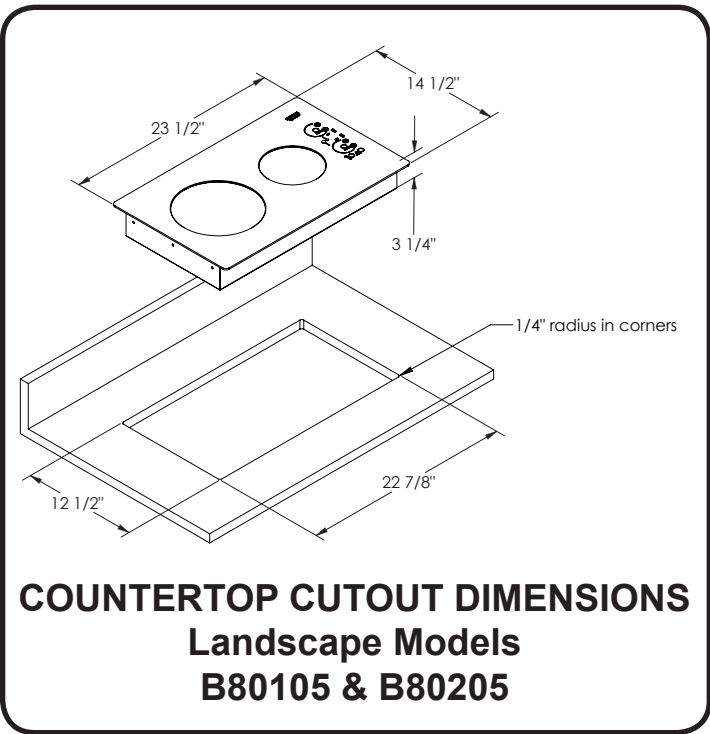
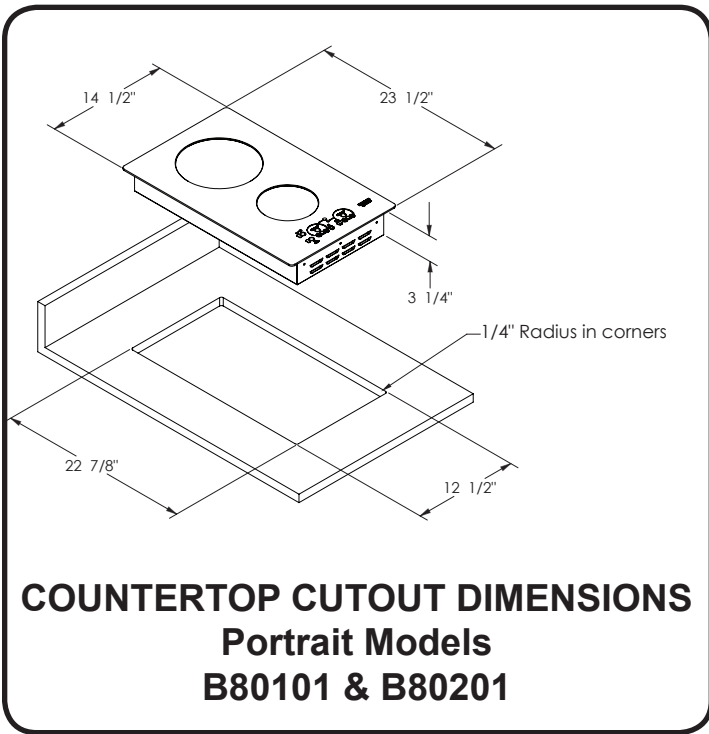

Fig. B

Allow a 2” minimum clearance between the bottom of the metal pan of the cooktop and any combustible surface located below, ie: the upper edge of a drawer installed below the cooktop (see Fig. B). Failure to provide proper clearance and ventilation may result in a fire hazard.



NOTE:
 When making countertop cutout, **radius** the corner of the cutout (1/4" radius is typical). This will prevent cracking of the countertop. Follow the countertop manufacturer's instructions regarding the minimum corner radius and reinforcement of corners.

STEP #4
Installing the Cooktop

There are two mounting brackets supplied with the glass ceramic cooktop. These brackets are designed to hold the cooktop firmly in place. The cooktop does not have a metal frame and should be bedded to the countertop using a soft bedding compound that will prevent damage if later removal for service is necessary. We recommend a very small bead of silicone sealant. If mounting in granite countertop use only 100% silicone sealant.

Attach the two mounting brackets supplied with the KENYON cooktop (as shown) to the inside vertical surface of the cutout. The brackets are to be mounted on opposing sides. Center the bracket in the opening, flush with the countertop and secure with long self-tapping screws that are provided. Position the cooktop in the cutout opening and press firmly on all sides to seal the frame into the bedding compound. Secure the cooktop to the brackets from underneath with the small sheet metal screws that are supplied.

BE CAREFUL NOT TO OVERTIGHTEN THE SCREWS.

STEP #5

Electrical Connection

Before proceeding further, verify that the power supply is disconnected. Verify that the appropriate electrical supply requirements have been met. Please refer to the table on page 5 for appropriate electrical requirements. The cooktop is supplied with a 36-inch long conduit for a connection to an accessible junction box. The 240V conduit consists of three insulated wires. There are two insulated hot lead conductors (red and black) and one insulated ground conductor (green).

Attach conductor wires to residence wiring in accordance with national, state and local electric codes.

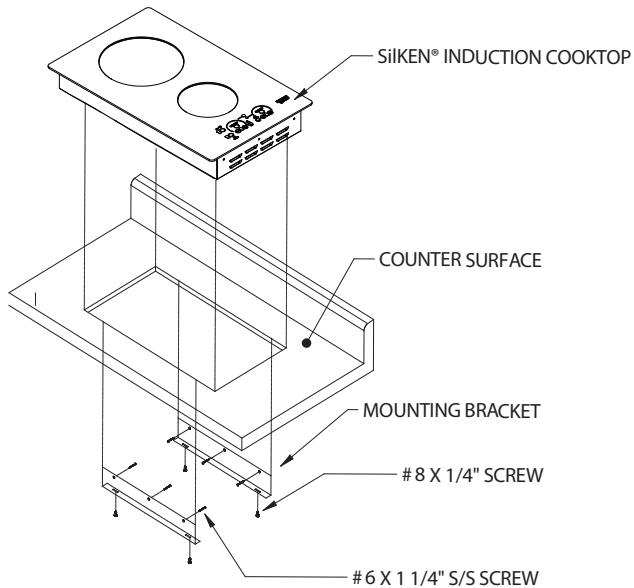

Warning - Grounding

The entire appliance must be grounded at all times when the electrical power supply is on. Do not ground the appliance with the neutral house supply wire (white). A separate ground must be used.

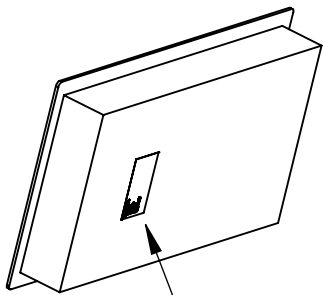

Name Plate
Label Location

STEP #6

Final Preparations Prior to Use

Remove the plastic film from the cooktop. Clean the cooktop before you use it for the first time. A thorough cleaning with a recommended cooktop cleaner (***Cerama Bryte Ceramic Cooktop Cleaner***) will provide a clean, shiny coating on the cooktop surface.

The next section of the manual covers cooktop use, maintenance and service information.

Please keep these instructions with the KENYON cooktop for future reference.

OPERATION

READ SAFETY INSTRUCTIONS BEFORE OPERATING YOUR APPLIANCE

The cooking surface areas of your SilKEN® induction cooktop are identified by inset induction zones patterns in the cooktop. The appliance is easy to maintain and easy to clean. Keeping the cooktop in top performance can be achieved by following the simple guidelines for use and cleaning below:

INDUCTION COOKING

In induction cooking, when a cast iron or magnetic pan is placed above the inset induction zone the generator under the glass produces a magnetic field which instantly generates heat in the cooking vessel. Induction cooking will not work with aluminum, copper or glass pots.

The ceramic glass surface itself does not generate heat. When the induction generator is activated, the steel cooking vessel immediately begins to heat up.

COOKWARE

Induction only works with cookware made of ferrous metals - metals to which magnets will stick such as cast iron and magnetic stainless steel, and will not work with aluminum or other metals. To test your cookware for induction cooking simply place a magnet on the bottom of the pot or pan and see if it sticks. If the magnet does not stick to your cookware it will not work.

Use cookware that will fit the burner size and has a flat bottom. By using cookware with the correct diameter, you should achieve maximum heating efficiency with the shortest possible boiling times.

Be certain that both the cooktop panel and the bottom of your pots and pans are clean and dry before use. By doing so, you will help prevent scratches and stains.

BENEFITS OF INDUCTION COOKING

Once the appropriate cookware is placed on the surface, heat is immediately generated. The SilKEN® induction cooktop will heat up to 50% faster than electric and gas cooktops.

By way of background, induction cooking is the most energy efficient method of cooking. It's as much as 50% more efficient than gas cooking appliances. The magnetic energy is directly supplied to the cookware so 85% to 90% of the electrical power applied to the cooktop is used to generate heat in the cooking vessel.

The SilKEN® induction cooktop provides spill retention but if a spill or overflow does occur the surface of the cooktop remains relatively cool and the excess liquid should not stick. Wait until the surface has cooled before you attempt to clean.

LOCK MODE

In lock mode the heat setting cannot be changed, but the off function for both induction elements and master power will still function for safety reasons. A light next to the “key” graphic will indicate that the cooktop is locked. Refer to figure C.

To lock the cooktop, place finger on the circular area next to the key graphic and hold for 1.5 seconds. An audible beep will be heard and the light next to the key graphic will illuminate. The cooktop is now locked.

To unlock the cooktop, touch the circular area next to the key graphic and hold for 1.5 seconds. An audible beep will be heard and the light next to the key graphic will go out. The cooktop is now unlocked and all functions operate.

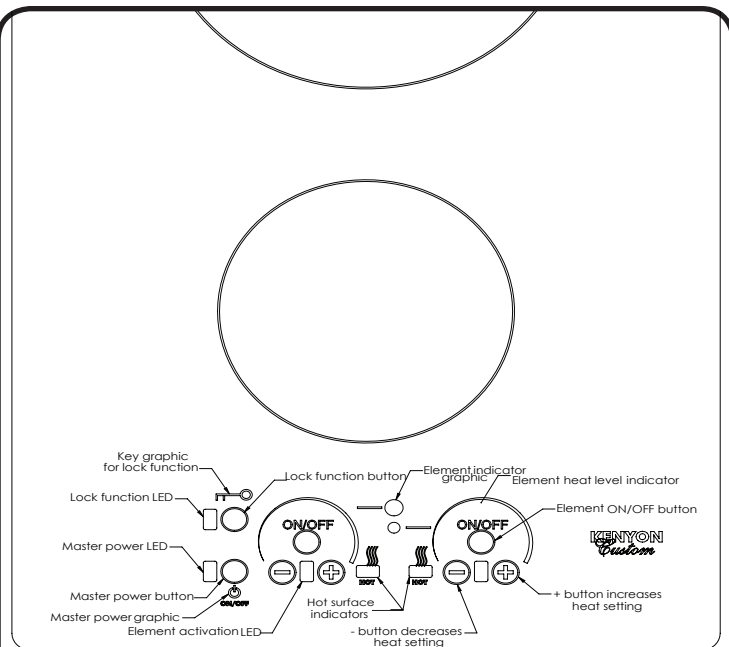

Fig. C

NOTE:

If the cooktop is locked and the master power is turned off, the cooktop will still be in lock mode the next time the master power is turned on and will need to be unlocked before any other functions are operable. Also, if cooking while locked and the master power is turned off, when the master power is turned back on, the previously energized induction element(s) will default to off, and the cooktop remains locked. These are important safety features, which allow the user to lock the cooktop and turn the master power off, providing a safe environment in which the cooktop cannot be turned on or elements activated unintentionally.

INITIAL START-UP

The induction cooktop is designed with a 2 step ON, and one step OFF for safety reasons, requiring at least 2 different touches of the controls to activate an element, but only one touch to deactivate an element or the entire unit.

Clean the cooktop before you use it for the first time. A thorough cleaning with our recommended cooktop cleaner (**Cerama Bryte Ceramic Cooktop Cleaner**) will provide a coating on the cooktop prior to its first use. A sample is included with your Kenyon cooktop. The induction cooktop surface should be free of any foreign substances before use.

CONTROLS OF INDUCTION COOKTOP

To activate an induction element, first the master power must be turned on by placing and holding a finger over the circular area next to the master power graphic. An audible beep will be heard and a light next to the master power graphic will illuminate. Then the desired induction element must be turned on, by placing a finger over the circular area marked ON/OFF for that element. The same beep will sound and a light will illuminate. Then the heat level is chosen, by holding a finger over the circular areas marked with + or -. Touching the + first will incrementally set the heat level from settings 1 thru 8 with a beep and corresponding number of lights illuminated. Touching the - first will incrementally set the level from settings 8 thru 1 with a beep and corresponding number of lights illuminated. When the desired heat level is reached the finger is removed and the cooktop remains at that heat level. If an induction element is activated, but no heat level chosen, the element will automatically turn off in 7 seconds.

To change the heat level place finger on + or - graphic of desired induction element to change heat level incrementally up or down.

To deactivate an element, touch circular area marked ON/OFF to turn the element off. Also the master power ON/OFF can be touched and the entire cooktop will be deactivated.

NOTE:

If no cookware or a non-magnetic pan is placed on an induction element after activation, the heat level lights will blink for 30 seconds and the element will turn off automatically. The same will happen if a pan is removed from the cooktop while cooking. If the pan is returned within the 30 seconds, the cooktop will resume operation at the previous heat level.

HEAT BOOST MODE

Heat boost mode increases power on one induction element by directing power from the other element. Heat boost is designed for frying foods and can be used to boil water instantly.

To activate Heat Boost, activate the element you wish to use and set heat level to setting 8 (highest). Touch the + one more time and the element will go into heat boost mode. A beep will be heard and a small light will illuminate near the element indicator graphic. Power from the other element will automatically be diverted to the element in heat boost mode. If the other element is on heat level 8 (high) the heat setting will be reduced. This will be seen in the number of lights illuminated in the heat level graphics.

HOT SURFACE INDICATOR

A hot surface indicator light will illuminate when the induction surface temperature rises above 140°F (60°C). A light will be seen near the "HOT" graphic for the corresponding element. The "HOT" light will remain illuminated until the surface temperature is below 133°F (56°C). The "HOT" light will continue to operate even when the unit is powered off.

SAFETY THERMAL CUTOUT

Another safety feature of the induction cooktop is the thermal cutout. If the temperature of either induction element reaches 518°F (270°C), the thermal cutout will open and power to both induction elements will be turned off. This is an important safety feature designed to reduce the risk of runaway temperatures and possible risk of fire if a pot is boiled dry or unintentionally put on the cooktop empty.

MASTER OFF

To power off both induction elements simultaneously, touch the circular area next to the master power ON/OFF graphic. Refer to figure C. This can be done without deactivation of the induction elements if any are in operation, and is an important safety feature allowing the user a “one touch off” in case of emergencies. All functions will no longer operate until the master power is turned on again.

COOLING FAN

Your Kenyon SilKEN® comes equipped with a cooling fan that automatically turns on to cool off internal parts. The fan will automatically turn off when cooling is no longer necessary. During long usage the fan may remain on even after the cooktop has been powered down.

TEMPERATURE SETTING GUIDE

SETTING	USES
1 Bar	Melting butter and chocolate Heating delicate sauces Warming food
2 Bars	Simmering sauces Steaming rice Melting large quantities
3-5 Bars	Steaming vegetables Heating soups, puddings and milk Simmering Frying
5-7 Bars	Sauteing Quick frying Browning Fast boiling of large quantities
8 Bars	Boiling water Heating soups Deep frying
HEAT BOOST MODE	Rapid boiling High temperature frying

CLEANING

To help ensure that the KENYON cooktop stays clean, follow these easy-care tips:

Lock the cooktop before cleaning by touching and holding the key symbol for 2 seconds.

Always remove food spills, grease spatters and metal rub-off from cookware. A razor blade scraper or the equivalent works well to remove spillovers.

Clean the cooktop with a paper towel or a clean, soft cloth and a recommended cleaner. After cleaning, always wipe the cooktop with a clean, damp cloth to avoid cooked-on cleaner residue. Wipe the cooktop dry.

Do not use a dish towel or sponge to wipe off the cooktop as a film may be left by the detergent and may cause discoloration of the cooktop surface.

Avoid abrasive scouring cleaners of any kind. Also avoid using plastic, nylon or metal cleaning pads. They may scratch or melt onto the cooktop.

Avoid chemical cleaners such as chlorine bleach, ammonia, hydrofluoric acid or chemical oven cleaners. They can etch or discolor the surface.

Do not let anything that melts - plastic, aluminum foil, sugar, etc. come into contact with the cooktop surface when it is hot. Should something melt onto the surface, *immediately* move it to a cool area of the cooktop with a razor blade scraper and then remove it from the cooktop as soon as possible.

SILKEN® Maintenance

The Kenyon induction cooktop is a sealed unit that does not require regular maintenance. Please follow our operating instructions as mentioned above. If your SilKEN® requires service, this must be preformed by **Authorized Personnel only**. Please call **Kenyon Customer Care** at **860-664-4906**.

TROUBLESHOOTING GUIDE

If your Kenyon SilKEN® induction cooktop has any problems or is not functioning please follow this simple troubleshooting guide before calling **Kenyon Customer Care**.

SILKEN® Cooktop Is Not Functioning Properly

- Cooktop is in lock mode, touch and hold the key symbol for 2 seconds to unlock the control panel.

<p>SilKEN® Cooktop Is Not Functioning Properly</p>	<ul style="list-style-type: none"> • Combination of LED's in horseshoe flashing repeatedly. Clear by cycling off power in circuit which supplies cooktop. • Check household fuse or circuit breakers to see if it has been blown or tripped. • No electricity is being supplied to the cooktop. Have a qualified electrician verify that the cooktop is connected to a proper electrical circuit.
<p>SilKEN® Induction Elements Are Not Heating Properly</p>	<ul style="list-style-type: none"> • Cooktop is not properly connected to electrical circuit. Have a qualified electrician verify the proper voltage is being supplied to the cooktop. • Electrical connection is loose. Have a qualified electrician tighten electrical connections
<p>Food Will Not Heat Properly</p>	<ul style="list-style-type: none"> • Incorrect cookware is being used. Please review our cookware section which is outlined on page 9.
<p>Control Panel Blinks and Cooktop Will Not Operate</p>	<ul style="list-style-type: none"> • Incorrect cookware is being used. Please review our cookware section which is outlined on page 9.

Warranty

Kenyon International, Inc (the "Company") warrants its products in normal usage to be free of defects in materials and workmanship subject to the conditions and limitations below.

Any part, which proves to be defective in normal usage during the warranty period will be repaired or replaced by the Company.

This warranty covers certain products built by the Company and is subject to the following conditions and limitations:

1. The Company's liability shall be limited to repair or replacement (choice of remedy at Company's option) of goods or parts as may be defective in materials or workmanship. This liability is limited to three years from the date of original installation or 42 months from invoice date, whichever comes first; this warranty covers parts and labor at approved Company rates, \$75 per hour.
2. Determination of suitability of the product for the use contemplated by the buyer is the sole responsibility of the Buyer and the Company shall have no responsibility in connection with such suitability.
3. The Company shall not be liable for any damage resulting from:
 - failures due to use of the product in applications for which they are not intended;
 - failures due to corrosion, wear and tear, abuse or improper installation or maintenance.
4. The Company shall be responsible for ground shipping charges to the location of the appliance (home) within the Continental United States and Canada. Any duties, express or special shipping charges are at the expense of the Buyer.
5. All labor allowed by the Company under this warranty must be performed by an Authorized Kenyon International Service Center, unless otherwise specified in writing by the Company.
6. This warranty does not cover the cost of repair or replacement due to damage of any glass surface, cooking grates or cooking griddles.

THERE ARE NO OTHER WARRANTIES OF MERCHANTABILITY, FITNESS FOR PURPOSE OR ANY OTHER KIND, EXPRESSED OR IMPLIED AND NONE SHALL BE IMPLIED BY LAW. The duration of any such warranties that are nevertheless implied by law for the benefit of a consumer, shall be limited to a period of three years from original purchase by the user. Some countries do not allow limitations on how long an implied warranty lasts, so this limitation may not apply to you.

THE COMPANY SHALL NOT BE LIABLE FOR CONSEQUENTIAL OR INCIDENTAL DAMAGES ARISING FROM THE BREACH OF THIS WARRANTY, WHETHER EXPRESSED, IMPLIED OR STATUTORY. Some countries or states do not allow exclusion or limitation of consequential or incidental damages so this limitation or exclusion may not apply to you.

THIS WARRANTY GIVES YOU SPECIFIC LEGAL RIGHTS AND YOU MAY ALSO HAVE OTHER LEGAL RIGHTS THAT MAY VARY FROM COUNTRY TO COUNTRY AND STATE TO STATE.

Kenyon International, Inc.
P.O. Box 925 • 8 Heritage Park Road • Clinton, CT 06413 USA
Phone (860) 664-4906 FAX: (860) 664-4907